

3D Interaction Techniques

Hannes Kaufmann

Interactive Media Systems Group (IMS)
Institute of Software Technology and
Interactive Systems

Based on material by Chris Shaw, derived from Doug Bowman's work



Copyright © 1996 United Feature Syndicate, Inc.
Redistribution in whole or in part prohibited

Why 3D Interaction?

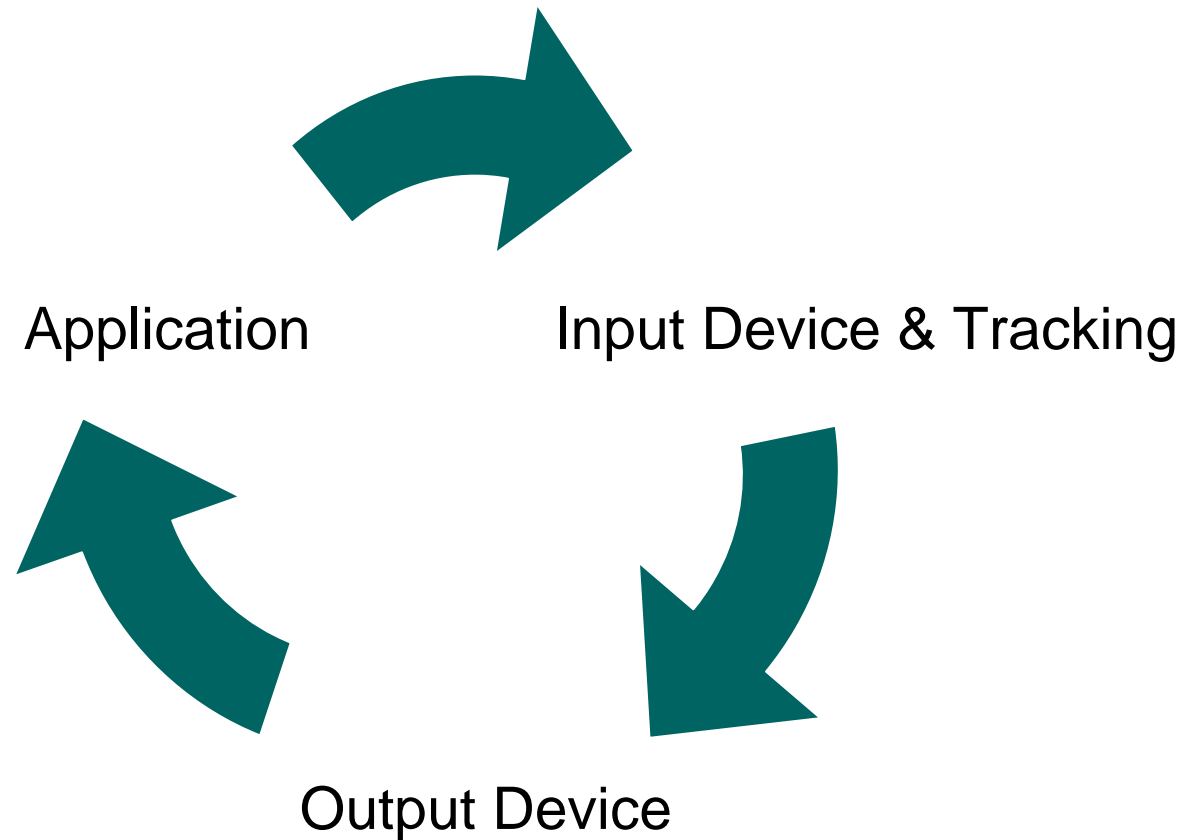

3D Interaction Techniques

- Methods used to accomplish a given **task** via the interface
 - Hardware components: Input & Output devices
 - Software components = *control-display mappings*: translating information from input devices to system actions -> display to user

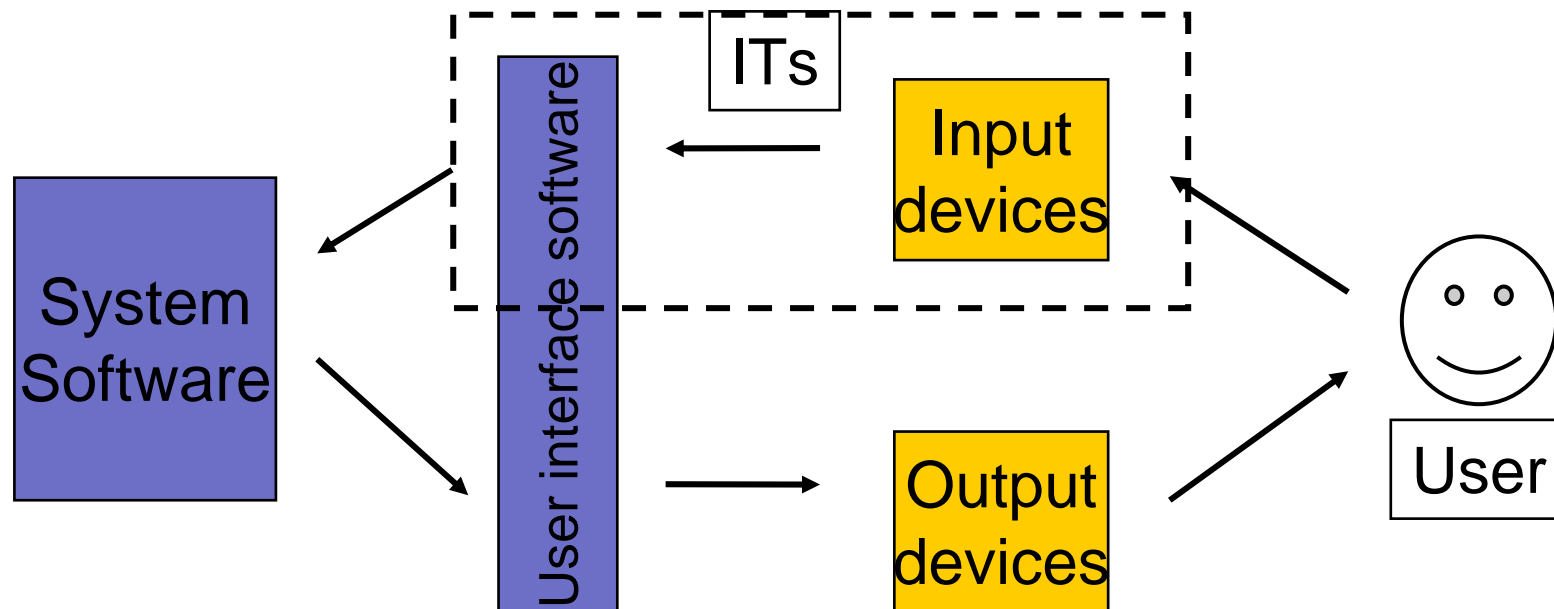

The Interface Challenge – The best of both Worlds

Naturalism: make VE & interaction work exactly like real world.

Magic: give user new abilities

Perceptual

Physical

Cognitive



The Interface Challenge

- Will the **cognitive overhead** required to use the interface **distract** users from the intended tasks and goals?

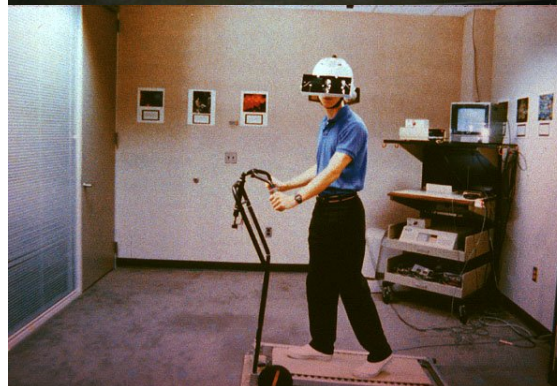

Goals of Interaction Design

- Performance
 - efficiency
 - accuracy
 - productivity
- Usability
 - ease of use
 - ease of learning
 - user comfort
- Usefulness
 - users focus on tasks
 - interaction helps users meet system goals

- But, most current VE apps either
 - are not complex interactively, or
 - have serious usability problems

What makes 3D Interaction difficult?

- Spatial input
- Lack of constraints
- Lack of standards
- Lack of tools
- Lack of precision
- Fatigue
- Layout more complex

Philosophies of Interaction Design

- Artistic approach
 - Intuition about users, tasks
 - Heuristics, metaphors
 - Aesthetics
 - Adaptation
- Scientific approach
 - Formal analysis
 - Formal evaluation
 - Performance requirements

Own Experience:

Combination of both gives best results!

Universal Interaction Tasks

- **Selection**: picking object(s) from a set
- **Manipulation**: modifying object properties (esp. position/orientation, shape, color,...)
- **Navigation**
 - Travel – motor component
 - Wayfinding – cognitive component; decision making
- **System control**: changing system state or mode
- **Symbolic input** (covered in Input Devices Part 1)
- **Modeling & Other tasks** (create and modify 3d Obj.)

Selection & Manipulation

Goals of Selection:

- Indicate action on object
- Make object active
- Travel to object location
- Set up manipulation

Isomorphic vs. Nonisomorphic

- Isomorphic:
 - strict, geometrical 1:1 correspondence between physical <-> virtual world
 - Most natural
 - Imitates physical reality and its limitations
- Nonisomorphic:
 - Magic virtual tools that extend working volume or arm length
 - Depends on application
 - Majority of manipulation techn. nonisomorphic

Selection performance

- Variables affecting user performance
 - Object distance from user
 - Object size
 - Density of objects in area

Common Selection Techniques

- Pointing
 - Touching with virtual hand/pointer
 - Ray casting
 - Cone casting; Aperture
 - Two-handed pointing
 - Image plane
- Naming (speech rec.)
- Indirect selection

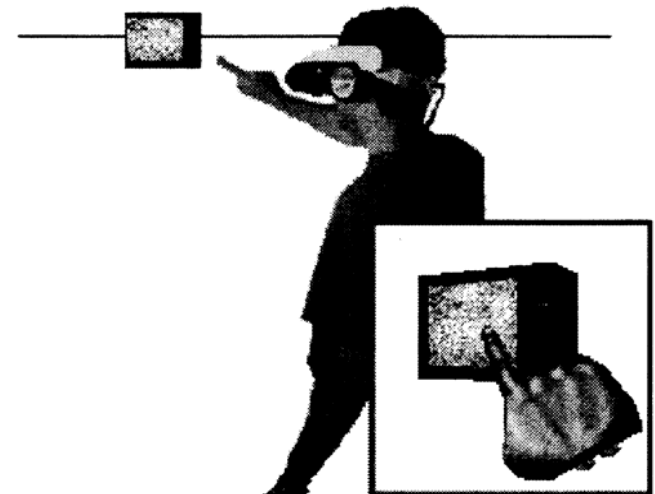

Enhancements to Basic Techniques

- Arm-extension
 - Go-Go Technique (mapping)
 - Fishing-Reel Technique (additional device: distance)
- World in Miniature (WIM)
 - Select icon-like objects

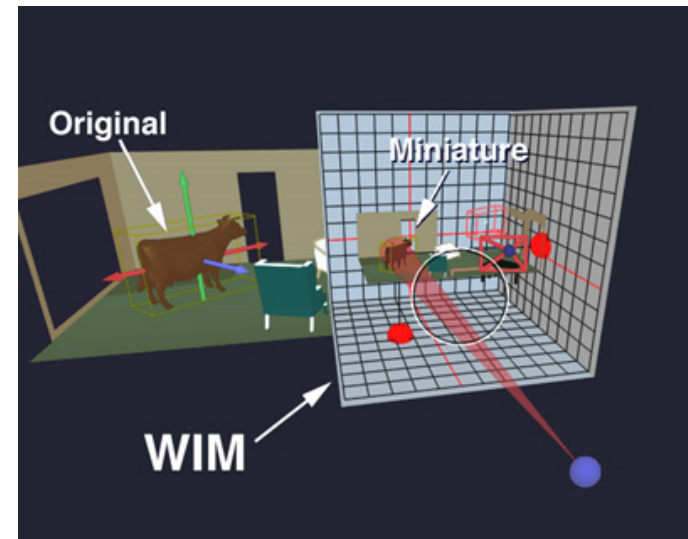
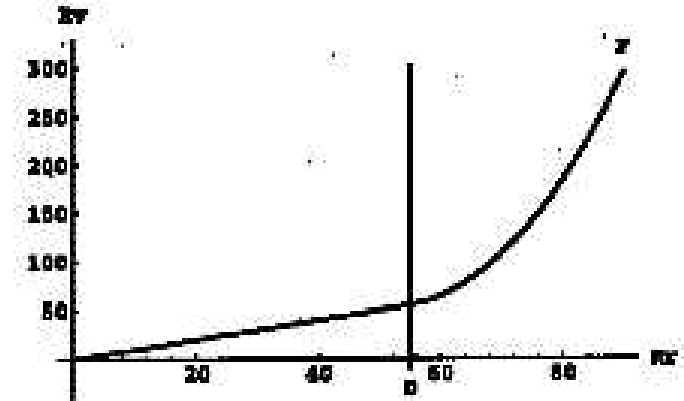

Technique Classification by Metaphor

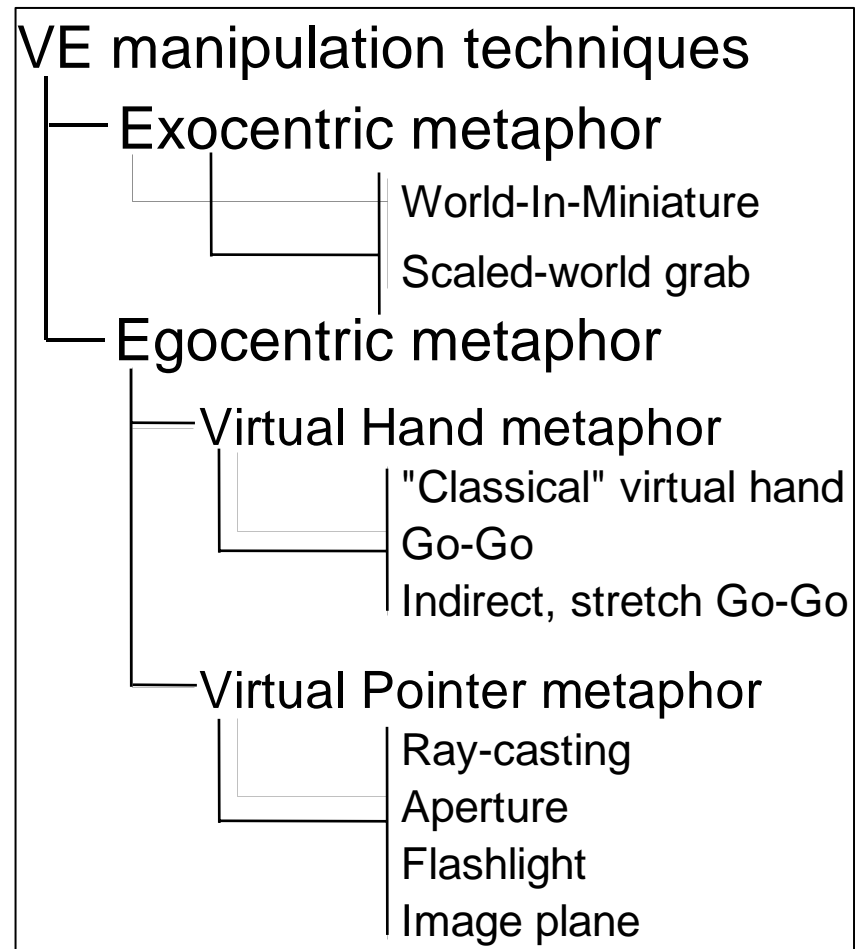

Selection: Task Decomposition

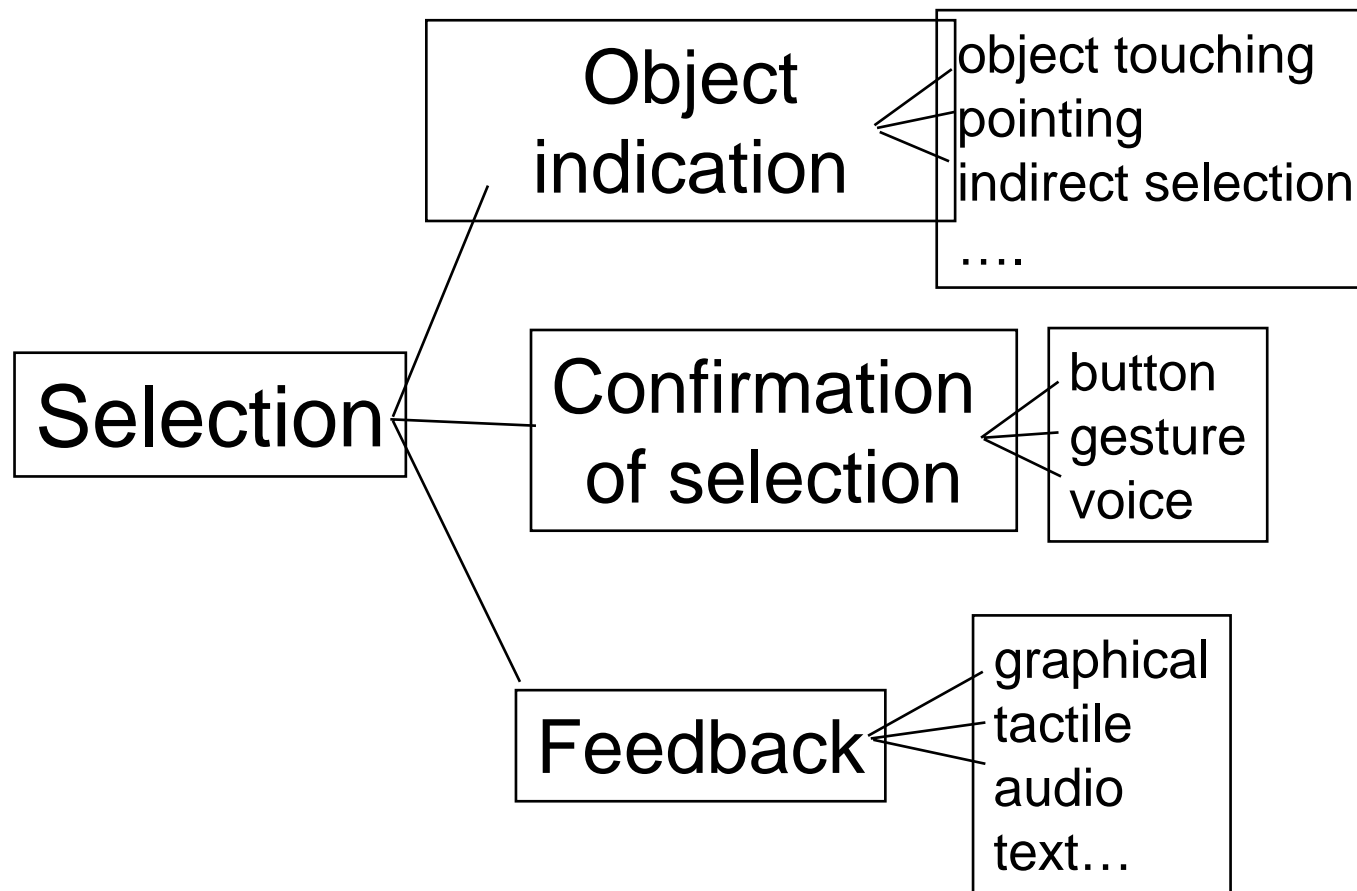

Evaluation: Selection Task

- Ray-casting and image-plane generally more effective than Go-Go
 - Exception: selection of very small objects can be more difficult with pointing
- Ray-casting and image-plane techniques result in the same performance (2DOF)
- Image-plane technique less comfortable

Goals of Manipulation

- Object placement
 - Design
 - Layout
 - Grouping
- Tool usage
- Travel

Variables affecting user performance

- Required translation distance
- Amount of rotation (avoid clutching)
- Required precision of placement

Manipulation Metaphors 1

- Simple virtual hand
 - Natural, easy placement
 - Limited reach, fatiguing, overshoot
 - 1:1 position mapping
- Ray casting
 - little effort required
 - Exact positioning and orienting very difficult (lever arm effect)
- Indirect depth mapping
 - Infinite reach, not tiring
 - Not natural, separates DOFs

HOMER technique

Hand-Centered
Object **M**anipulation
Extending **R**ay-
Casting

- Select: ray-casting
- Virtual hand moves to object
- Manipulate: hand

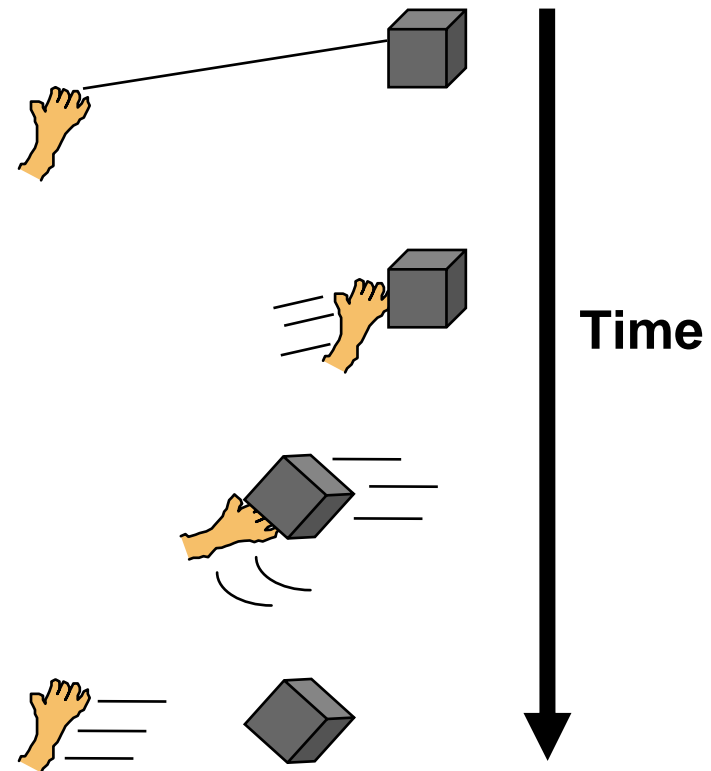

Manipulation Metaphors 2

- HOMER (ray-casting + arm-extension)
 - Easy selection & manipulation
 - Expressive over range of distances
 - Hard to move objects away from you
- Scaled-world grab
 - Selection by image plane
 - World scaled down around virtual hand
 - Easy, natural manipulation
 - Hard to move objects away

Manipulation Metaphors 3

- World-in-miniature
 - All manipulation in reach
 - Doesn't scale well for large environments
 - Indirect

Classification by Components

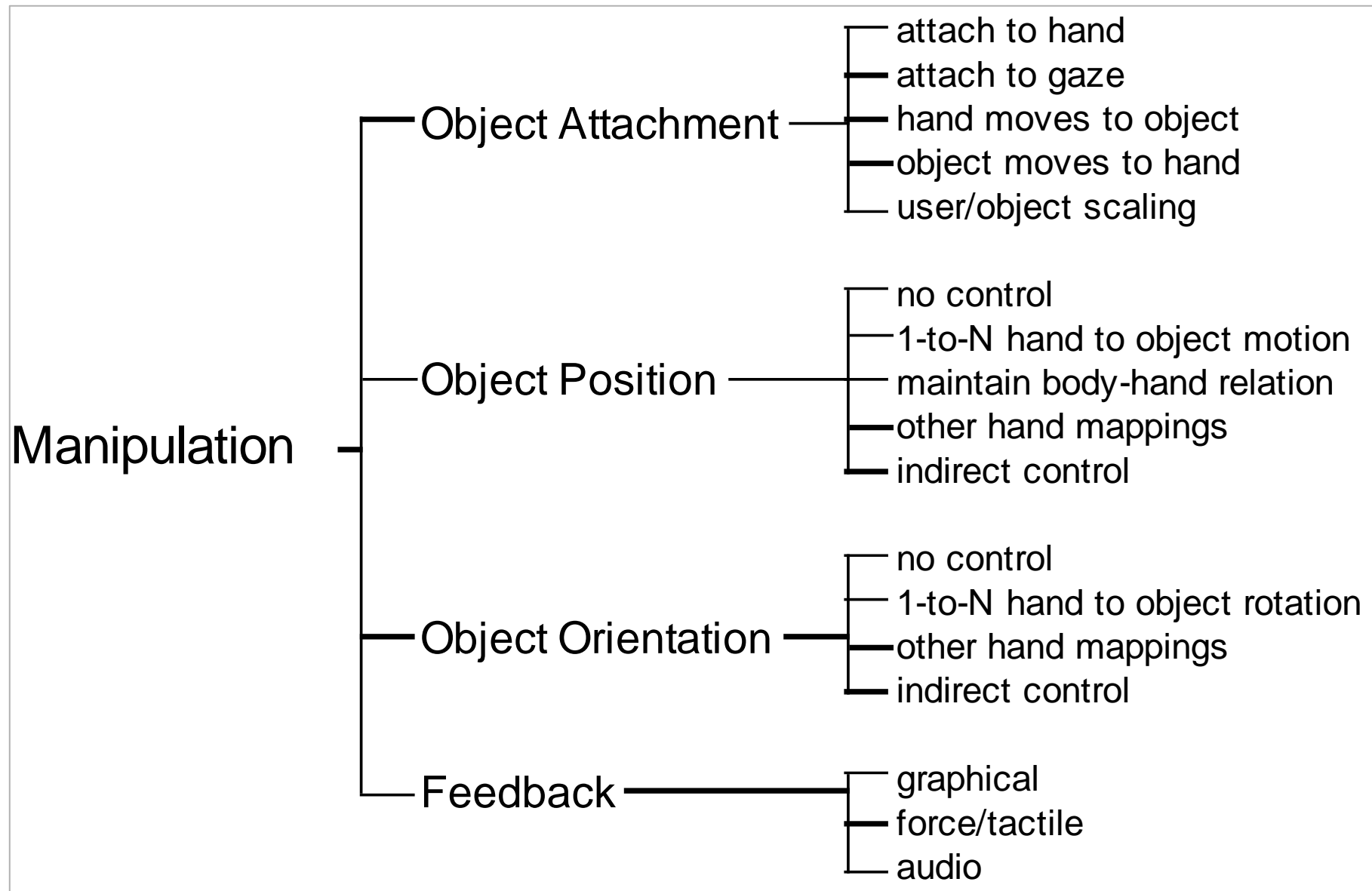

Evaluation: Positioning Task

- Ray casting effective if the object is repositioned at constant distance
- Scaling techniques (HOMER, scaled world grab) difficult in outward positioning of objects: e.g. pick an object located within reach and move it far away
- If outward positioning is not needed then scaling techniques might be effective

Evaluation: Orientation Task

- Setting precise orientation can be very difficult
- Shape of objects is important
- Orienting at-a-distance harder than positioning at-a-distance
- Techniques should be hand-centered

Manipulation notes

- No universally best technique
- Constraints and reduced DOFs
- Naturalism not always desirable
- If VE is not based in the real, design your environment for optimal manipulation

Travel

- Motor component of navigation
- Movement between 2 locations
- Setting the position (and orientation) of the user's viewpoint
- Most basic and common VE interaction technique
 - used in almost any large-scale VE

Travel Tasks

- Exploration
 - travel which has no specific target
 - build knowledge of environment
- Search
 - naive: travel to find a target whose position is not known
 - primed: travel to a target whose position is known
 - build layout knowledge
 - move to task location
- Maneuvering
 - travel to position the viewpoint for a task
 - short, precise movements

Traveling metaphors 1/2

- **Steering** metaphor: continuous specification of direction of motion

- gaze-directed
- Pointing (the “fly” gesture)
- physical device (steering wheel, joystick)
- Examples: [Beckhaus – chair \(video\)](#)



- **Target-based** metaphor: discrete specification of the goal location

- point at object
- choose from list
- enter coordinates
- Example: [Reitmayr - Outdoor](#)

Traveling metaphors 1/2

- **Route-planning** metaphor:
one-time specification of path
 - place markers in world
 - move icon on map

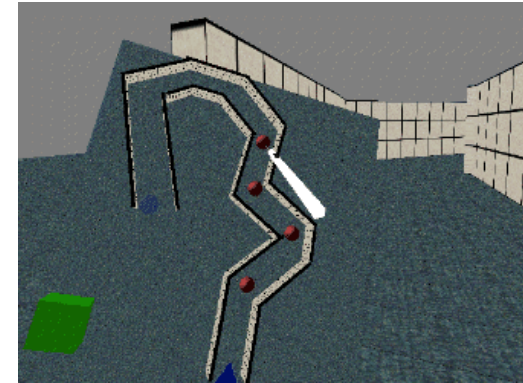

- **Manipulation** metaphor: manual manipulation of viewpoint
 - “camera in hand”
 - fixed object manip.
 - Example: film camera movement
 - Grabbing in the air technique (2 gloves)



“Natural” travel metaphors

- Walking techniques
- Treadmills
- Bicycles
- Other physical motion
 - VMC / Magic carpet
 - Disney’s river raft ride
 - Simulation of flying



Evaluation results (by Bowman)

- “Teleportation” can lead to significant disorientation
- Env. complexity affects info. gathering
- Travel IT and user’s strategies affect spatial orientation

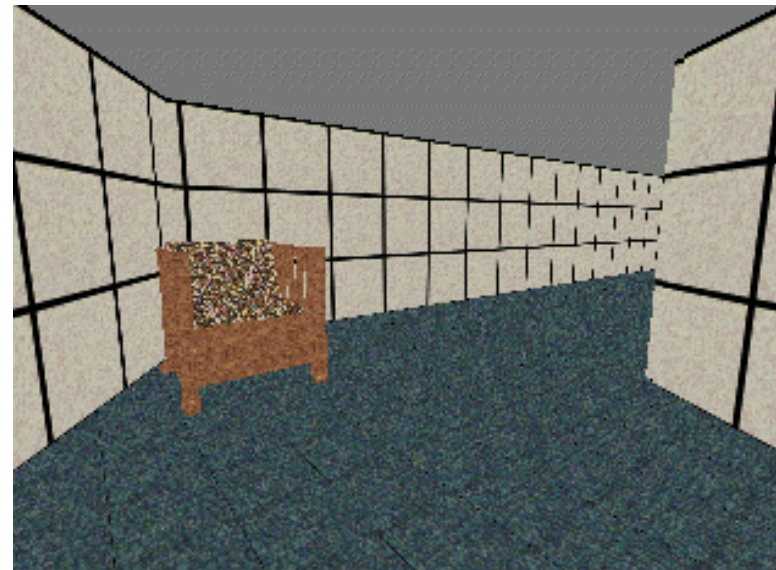

Evaluation results – 2

- Steering techniques best for naive and primed search
- Map-based techniques not effective in unfamiliar environments, or when any precision is required

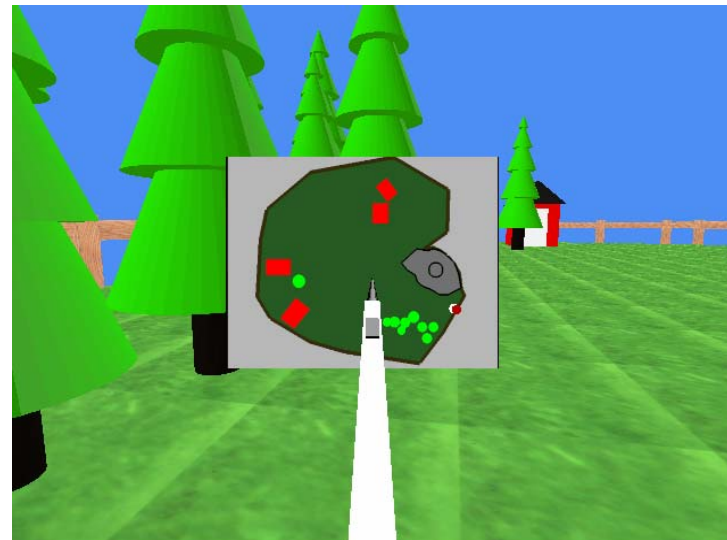

Myths

- *There is one optimal travel technique for VEs.*
- *A “natural” technique will always be better than another technique.*
- *Desktop 3D, workbench, and CAVE applications should use the same travel ITs as HMD-based VEs.*

Design guidelines

- Make simple travel tasks simple (target-based techniques for motion to an object, steering techniques for search).
- Provide multiple travel techniques to support different travel tasks in the same application.
- Use transitional motions (not teleportation!) if overall environment context is important.

System control

- Catch-all for other types of VE interaction
 - Issuing command
 - Changing mode
 - Choosing tool
- Often composed of other tasks

Common types of system control techniques

- Menu systems
- Voice commands
- Gestures/postures
- Implicit control (e.g. pick up new tool to switch modes)

Floating menus

- Requires user knowledge
- Can occlude environment
- Using 3D selection for a 1D task
- Can be difficult to find
- Very bad design - AVOID

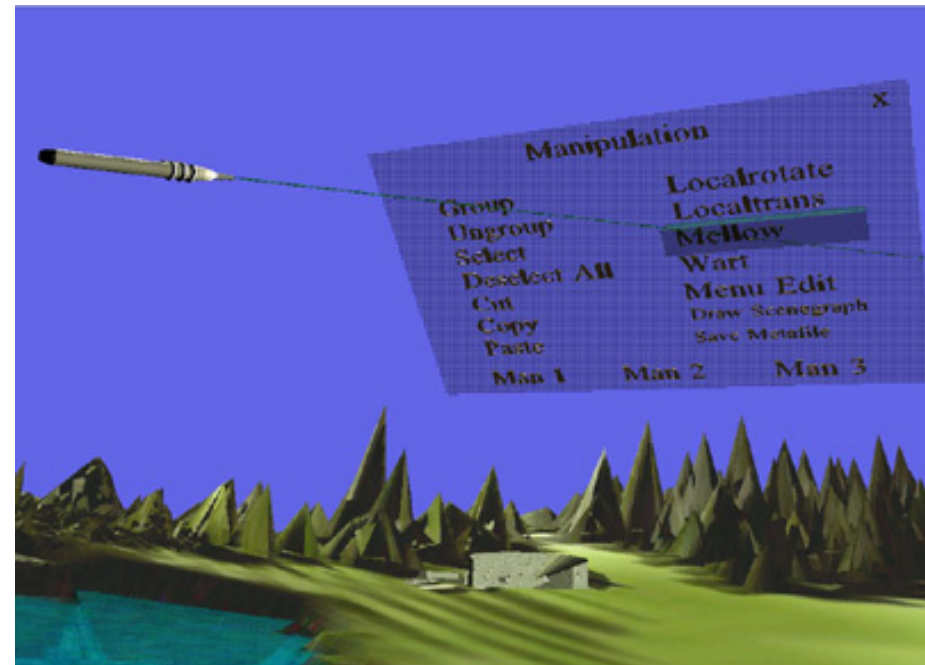

Pop-Up Menus - Radial

- Sundial
 - Pie menu with 3D selector
 - User rotates “Shadow stick” to occlude desired segment
- Example: [iOrb](#)



1 DOF menu

- Correct number of DOFs for the task
- Can be put away
- Only one menu level at a time

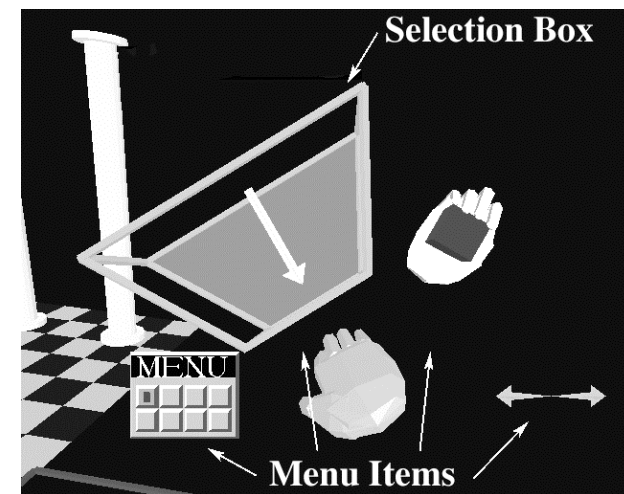
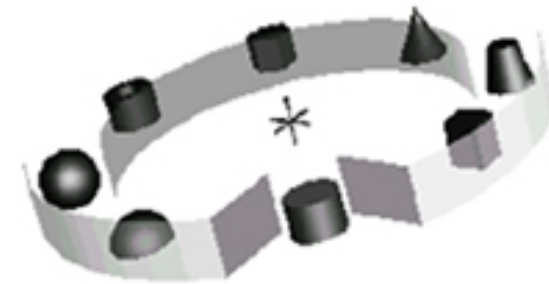

Pen & Tablet Interaction

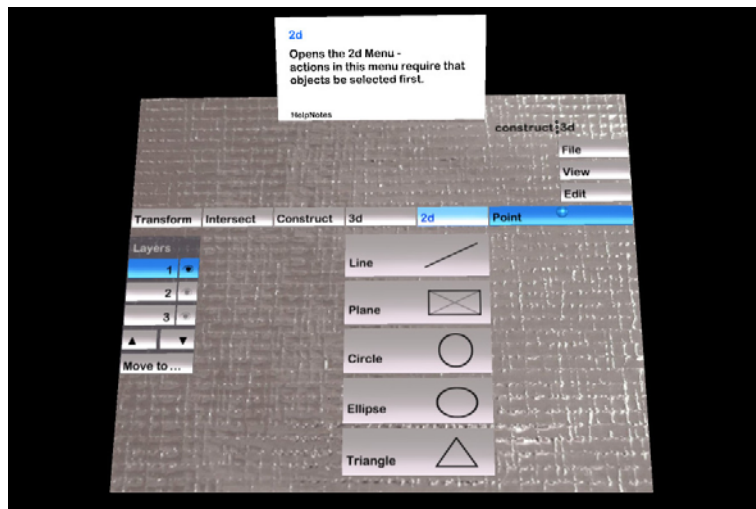

Pen & Tablet Interaction

Tablet = real object:

- Can put away
- Handwriting input possible
- Can be used as a clipboard
- Constrained surface for input
- Usability: People are used to 2D input

- Combine 2D/3D interaction
- Use any type of 2D interface, not just menus

Pen:

- Direct manipulation
- [Magic Lens Metaphor](#)

2D interaction in a 3D world

- Quite useful for appropriate tasks
- Can integrate seamlessly with 3D
- If presence is important, the 2D interface should be *embedded*, not *overlaid*

Applications - Examples

- Real applications always **combine** interaction techniques

Examples:

- Projection Screen Interaction e.g. [ArsBox](#)
- Volumetric Displays e.g. [Perspecta3D](#)
- ARToolkit Interaction: [Mozart MagicBook](#)
- New Device: [Handheld HMD](#)

Literature

- 3D User Interfaces – Theory and Practice
Doug Bowman, Ernst Kruijff, J. LaViola,
Ivan Poupyrev; Addison Wesley, 2005.

Prüfung: MI 25.1.2006 – 14:15-15:45

- **Karlsplatz: HS 7 Schütte-Lihotzky Hörsaal**

Erdgeschoß

HS 7
(Schütte Lihotzky Hörsaal)

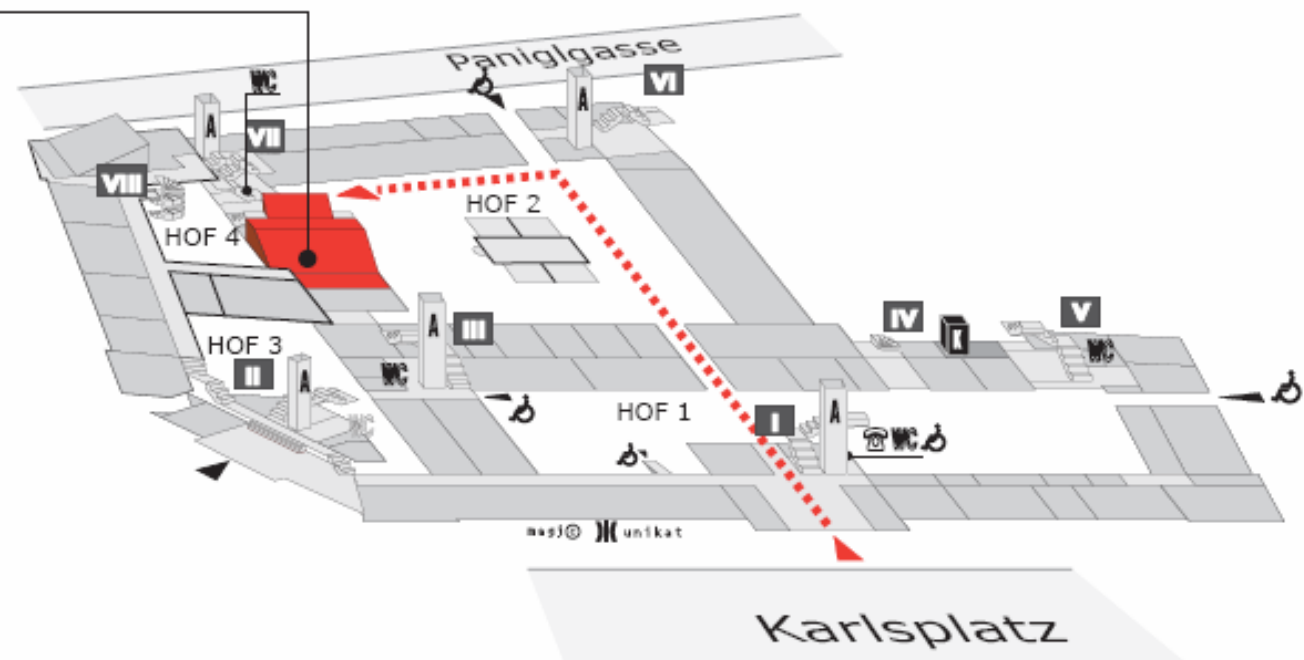

Vielen Dank
für die Aufmerksamkeit!

Fragen, Wünsche, Anregungen?